

www.aesmartconference.com

info@yihang-ts.com

Hubei Yihang New Material Technology Co., Ltd.

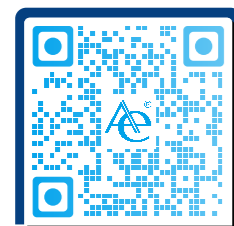

Official Website



AE SMART

ALL-SCENARIO · ONE-STOP SOLUTIONS

EMPOWERING EFFICIENT COLLABORATION SPACES

Solution for Conference | Teaching | Hotel | Control | Command



AE SMART

AE SMART specializes in smart meeting and collaboration space solutions, providing global channel partners, system integrators, and project customers with integrated products and services covering professional audio, video, paperless conferencing, LED displays, and intelligent control systems.

We offer a complete portfolio of hardware and software products, including professional AV equipment, paperless conference systems, LED display solutions, meeting control systems, as well as supporting products such as digital podiums, motorized lift terminals, operator consoles, and more — designed to meet the construction needs of various meeting spaces, educational environments, and command & control projects.

Focusing on the development trends of modern office and collaboration environments, AE SMART continuously enhances its product design and system integration capabilities, striving to help customers build more efficient, stable, and easy-to-manage collaboration spaces.

Backed by a mature product portfolio, reliable delivery capabilities, and extensive project experience, we consistently empower our partners to expand into government, enterprise, education, hospitality, and public service markets, working together to create more competitive project solutions.

We focus not only on the equipment itself, but also on how the equipment serves efficient collaboration between people and spaces.

OUR ADVANTAGES

- **Innovation Driven:** Leveraging our R&D center in Wuhan Optics Valley, AE SMART continuously drives innovations in collaboration technologies, AV applications, and intelligent control systems to enhance user experience and project value.
- **Integrated Manufacturing:** With modern manufacturing facilities and integrated production capabilities, AE SMART ensures consistent product quality and reliable delivery to provide long-term support for partners.
- **Integrated Solution Capability:** From meeting spaces and educational facilities to control rooms and command centers, AE SMART provides complete product portfolios and project-oriented support.
- **International Quality Standards:** Our products strictly follow quality management systems and comply with internationally recognized standards and certifications.
- **Future-Oriented Vision:** We continuously monitor the evolution of modern collaboration environments and enhance our product ecosystem and integration capabilities to help partners adapt to the requirements of future smart space construction.



FACTORY AND MANUFACTURING CAPABILITIES

AE SMART adheres to in-house original manufacturing, establishing a complete manufacturing system from R&D and design to large-scale delivery, ensuring product quality consistency and project delivery stability.

Our R&D center is located in Wuhan Optics Valley, where we continuously monitor the development trends of modern meeting collaboration and intelligent spaces, providing ongoing product optimization and technical support for audio-visual conferencing systems, paperless conferencing systems, and related applications.

With modern production facilities and a lean manufacturing management system, we have achieved standardized and controllable production processes — from key components to final assembly — ensuring stable performance and reliable delivery capability for every product across different project environments.

In addition, AE SMART offers flexible OEM/ODM collaboration capabilities, enabling product combinations and customization support tailored to the project requirements of our channel partners, covering digital podiums, motorized lift systems, meeting control devices, and related collaboration hardware.

AE SMART is committed to providing a stable, reliable, and sustainably deliverable product foundation for diverse application scenarios including government, enterprise, education, hospitality, and command centers, supporting partners in efficiently executing project deployments and long-term operations.



**ALL-SCENARIO · ONE-STOP SOLUTIONS
EMPOWERING EFFICIENT COLLABORATION SPACES**



CONTENT

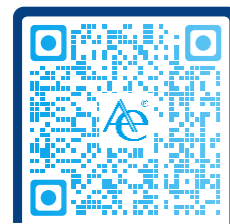

Get Data Sheets

01 Smart Conference System

Motorized Monitor

Motorized Retractable Monitor	03
Motorized Foldable Monitor	13
Armrest Display Solution	19

Electronic Nameplate

Motorized Retractable Nameplate	25
Liftable and Rotatable Electronic Desk Nameplate	27
Tabletop Nameplate	28

Manually Adjustable Monitor

Tabletop Foldable Monitor	21
Recessed Foldable Monitor	22
Tabletop Foldable Monitor with Mic & Clock	23

Microphone

Retractable Microphone Lift	29
-----------------------------	----

Software

Software	33
----------	----

Portable Projector

Portable Projector	31
--------------------	----

02 Desktop Socket

Round Type	37
Rectangle Type	41
M-Desktop Socket	45
Desktop Power Strip	49
Under-desk Power Strip	51
Public Phone Charging Station	55

03 Lectern

Digital Lectern	59
-----------------	----

04 Control Console

Operator Console	69
------------------	----

01 Smart Conference System

Digital Security · Real-Time Collaboration ·
Inclusive Access · Responsive Support



Motorized Monitor

Motorized Retractable Monitor



15.6" screen size available
10.1" nameplate in the back of screen available for option
Optional external microphone

ULTRA-THIN MOTORIZED RETRACTABLE MONITOR

AX-MUF SERIES

Keywords

- Ultra-narrow bezel
- Anti-glare treatment
- 40mm-wide cover plate
- Ultra-thin and light housing
- Safe, DC 12V power supply
- Dry contact for centralized control
- Embedded 10.1-inch nameplate
- Free nameplate software available
- Auto calibration for microphone
- Independent movement for monitor and microphone

Motorized Monitor

Motorized Retractable Monitor

CLASSIC MOTORIZED RETRACTABLE MONITOR

AX-MF/AX-FP/AX-G/AX-MG SERIES

10.1" nameplate in the back of screen available for option
Optional external microphone

Keywords

- Ultra-narrow bezel
- Anti-glare treatment
- Power loop reduces cables under the table
- Embedded 10.1-inch nameplate
- Free nameplate software available
- Auto calibration for microphone
- Independent movement for monitor and microphone

MANUFACTURING PROCESS CHOICES:



Option 1: Stamping-formed frame - Aluminum alloy back plate
(15.6" screen size)



Option 2: CNC-machined frame - Tempered glass back plate
(15.6"/17.3"/18.5"/21.5"/23.8" screen size available)



Motorized Monitor

Motorized Retractable Monitor



DIGITAL / SECURE / TRANSFORMATIVE

Transitioning to a fully digital meeting platform not only safeguards sensitive information by design, but also represents a truly transformative step in modernizing how organizations collaborate and make decisions.

PAPERLESS CONFERENCE SYSTEM: SECURITY ADVANTAGES

1. Enhanced Data Security and Information Control
This fully digital platform safeguards sensitive information through encrypted storage, granular access permissions, and detailed activity logs. It eliminates the risks associated with physical document mishandling or unauthorized access, ensuring confidentiality and compliance.

2. Efficient and Inclusive Collaboration
By enabling real-time content sharing, simultaneous annotation, and instant feedback from any location, the system transforms traditional workflows. This creates a more dynamic and inclusive meeting environment, breaks down geographical barriers, and seamlessly integrates remote participants.

3. Data-Driven and Agile Decision-Making
By digitizing the entire meeting process – from agenda distribution and minute-taking to task assignment – the system establishes a structured and traceable decision-making process. This allows faster consensus-building, automated follow-up actions, and easier performance tracking, and helps organizations execute strategies more effectively.



Motorized Monitor

Motorized Retractable Monitor



AX-FW SERIES

NO COVER PLATE MOTORIZED RETRACTABLE MONITOR

15.6"/17.3" screen size available



Keywords

- Ultra-narrow bezel
- Safe, DC 12V power supply
- Fast, single-way running in 4s
- Light enough to reduce shipping cost
- 9.5mm max. cutout on table surface

Motorized Monitor

Motorized Retractable Monitor



AX-N SERIES

SLOPE TYPE MONITOR INTEGRATED

15.6" screen size available

Keywords

- Ultra-narrow bezel
- Anti-glare treatment
- Elegant blend of black and silver
- Auto calibration for microphone
- 2.4-inch touch control panel
- Independent movement for monitor, nameplate, and microphone
- Power loop reduces cables under the table
- Free nameplate software available





EFFICIENT COLLABORATIVE SUSTAINABLE

Paperless Meeting System: Key Advantages

- 1. Maximum Efficiency & Focus:**
Eliminate all printing, distribution, and filing. Access and annotate documents in real-time on any device. Use integrated tools for instant voting, task assignment, and minute generation, streamlining the entire meeting workflow from preparation to follow-up.
 - 2. Enhanced Security & Control:**
Replace vulnerable paper with secure digital files. Apply granular permissions, watermarking, and detailed activity logs. Maintain full control over document access and sharing, ensuring confidentiality and a clear audit trail for sensitive discussions.
 - 3. Sustainable & Professional Impact:**
Drastically reduce paper consumption, waste, and your organization's carbon footprint. Demonstrate a commitment to environmental responsibility (ESG) while presenting a modern, technologically advanced corporate image.
- Empower smarter, secure, and sustainable collaboration.

Motorized Monitor Motorized Retractable Monitor



It transforms meetings with digital efficiency, seamless collaboration, and a strong commitment to sustainability.

Motorized Monitor

Motorized Retractable Monitor



15.6" screen size

MOTORIZED RETRACTABLE MONITOR

WITH NAMEPLATE AND MICROPHONE

AX-15MUFH-PRO

Keywords

- Ultra-narrow bezel
- Anti-glare treatment
- Safe, DC 12V power supply
- Ultra-thin and light housing
- 40mm-wide cover plate
- Dual-sided 7-inch nameplate
- Free nameplate software available
- Auto calibration for microphone
- Supports free combination of monitor, electronic nameplate, and microphone

Motorized Monitor

Motorized Retractable Monitor



Motorized Monitor

Motorized Foldable Monitor

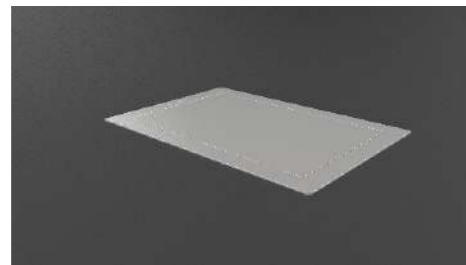
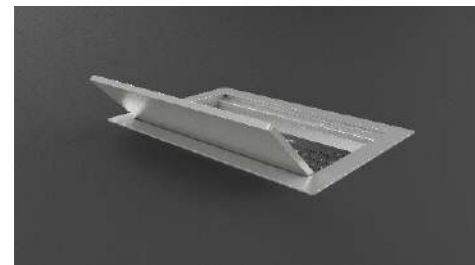

MOTORIZED FOLDABLE MONITOR

SFZ-D SERIES

17.3" screen size

Keywords

- Ultra-narrow bezel
- Anti-glare treatment
- Anti-Pinch Protection System
- Ultra-thin and light housing
- Cubby for mouse and keyboard
- Manually adjustable screen angle



Motorized Monitor

Motorized Foldable Monitor



Motorized Monitor

Motorized Foldable Monitor



MOTORIZED FOLDABLE MONITOR

FZ-W SERIES

15.6"/17.3"/21.5" screen size available

Keywords

- Ultra-narrow bezel
- Low noise
- Anti-Pinch Protection System
- Manually adjustable screen angle

Motorized Monitor

Motorized Foldable Monitor

MOTORIZED FLIP-UP MONITOR

WITH WIRELESS MOUSE AND KEYBOARD

FZ-D SERIES

15.6"/17.3"/21.5" screen size available

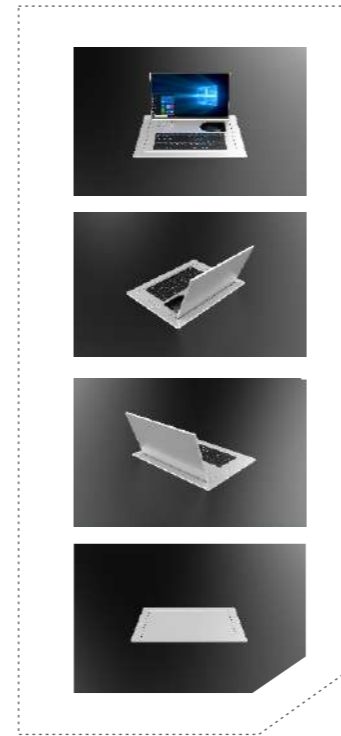

Keywords

- Ultra-narrow bezel
- Low noise
- Anti-Pinch Protection System
- Wireless mouse and keyboard
- Lightweight
- Manually adjustable screen angle

Motorized Monitor

Motorized Foldable Monitor



Motorized Monitor

Motorized Foldable Monitor



Motorized Monitor

Armrest Display Solution

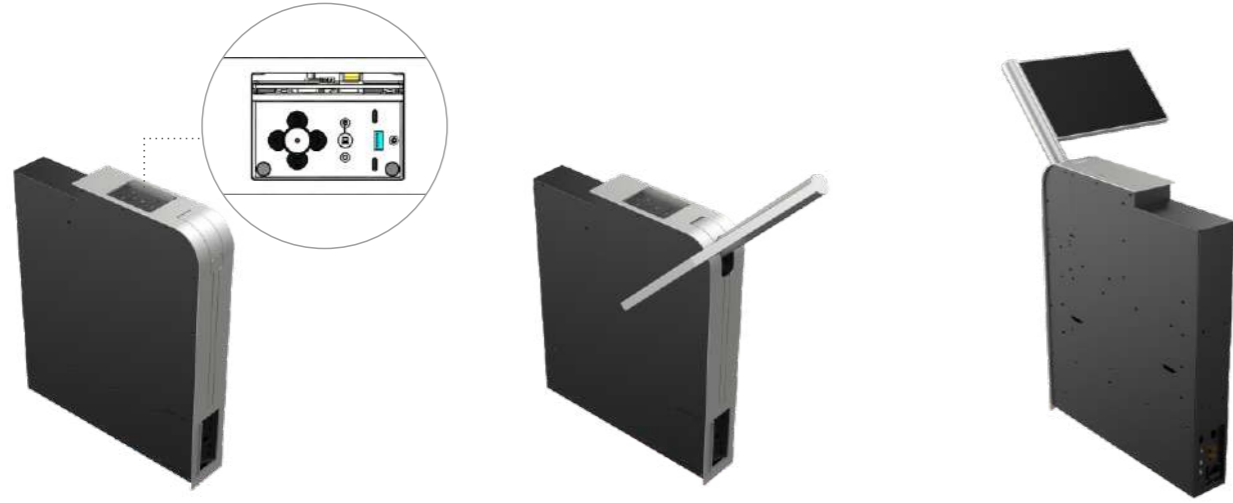

Keywords

- *Seamless hidden design – Fits perfectly into sofa armrests*
- *Electric lift & tilt – One-touch screen rise/fall with adjustable angle*
- *12.5" FHD touchscreen – 1920×1080*
- *Rich connectivity – Type-C, USB, HDMI, Gigabit Ethernet*
- *Easy centralized control – RS-485 plus optional control software*
- *Safe & reliable – AC 220V, built-in fuse, easy maintenance*

Motorized Monitor

Armrest Display Solution



ARMREST DISPLAY SOLUTION

Meeting rooms / Training rooms / Command centers / VIP lounges / Auditoriums

Manually Adjustable Monitor

Tabletop Foldable Monitor



TABLETOP MANUALLY FOLDABLE MONITOR

AX-E SERIES

15.6"/17.3"/21.5"/23.8" screen size available

Keywords

- Ultra-narrow bezel
- Anti-glare treatment
- Portable
- No table cutout required
- Safe, DC 12V power supply



Manually Adjustable Monitor

Recessed Foldable Monitor



RECESSED MANUALLY FOLDABLE MONITOR

AX-M SERIES

15.6"/17.3"/21.5" screen size available

Keywords

- Ultra-narrow bezel
- Anti-glare treatment
- No visible cabling
- Narrow table cutout
- Safe, DC 12V power supply

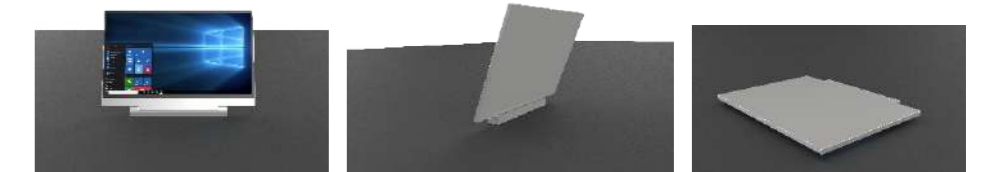

Manually Adjustable Monitor

Tabletop Foldable Monitor



TABLETOP FOLDABLE MONITOR WITH MIC & CLOCK

15.6" screen

Keywords

- *Ultra-narrow bezel*
- *Anti-glare treatment*
- *Portable*
- *No table cutout required*
- *Embedded electronic clock*

Manually Adjustable Monitor

Tabletop Foldable Monitor



Electronic Nameplate

Motorized Retractable Nameplate



MOTORIZED RETRACTABLE NAMEPLATE

SJZP3 SERIES

Keywords

- Dual-sided 7-inch nameplate
- Ethernet control
- Free nameplate software available

Electronic Nameplate

Motorized Retractable Nameplate



Electronic Nameplate

Liftable and Rotatable Electronic
Desk Nameplate

LIFTABLE AND ROTATABLE ELECTRONIC DESK NAMEPLATE

7"/8.8"/10.1"/10.9" screen size available

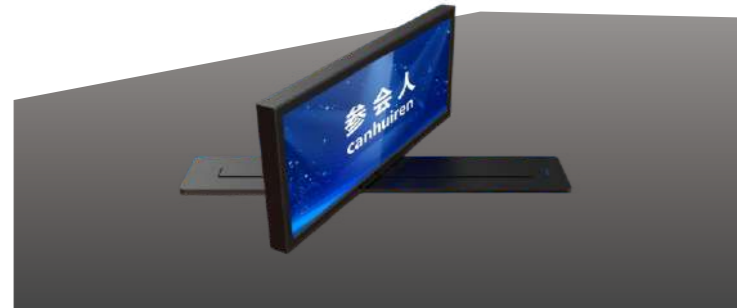

Keywords

- Supports $\pm 90^\circ$ rotation (left and right)
- Ethernet control
- Free nameplate software available
- Position detection prevents lifting before alignment, avoiding screen damage

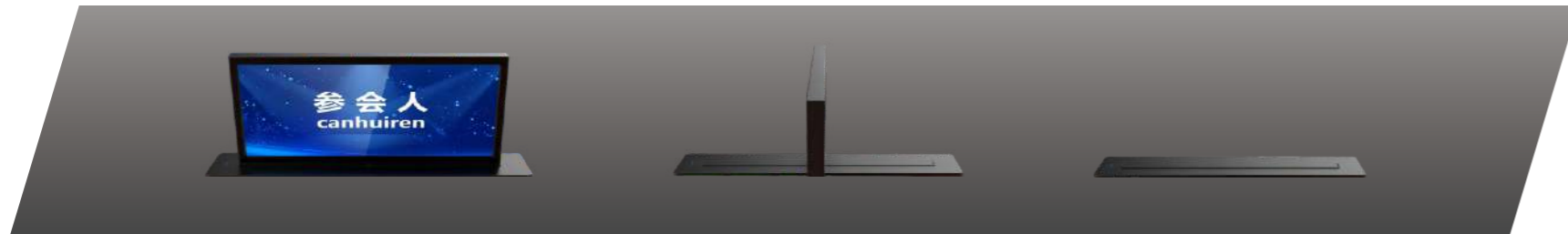

Electronic Nameplate

Tabletop Nameplate

TABLETOP NAMEPLATE

ZP9 SERIES

Keywords

- Dual-sided 7-inch nameplate
- Anodized aluminum surface coating
- Free nameplate software available

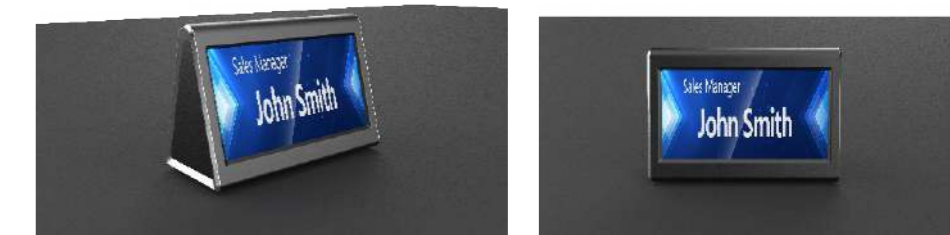

Microphone

Retractable Microphone Lift

RETRACTABLE MICROPHONE LIFT

SJHT2 SERIES

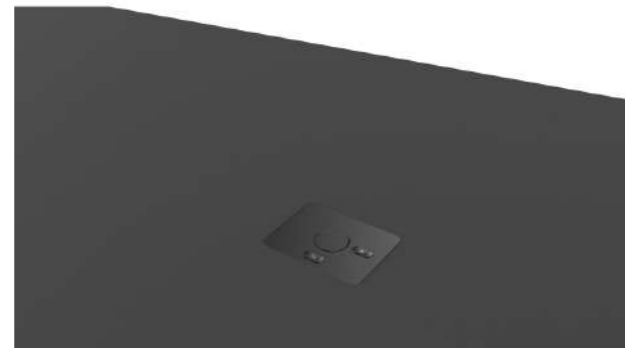

Keywords

- Auto calibration for microphone
- Compatible with mainstream conference systems
- Supports microphones up to 50 cm in length

Microphone

Retractable Microphone Lift





PORTABLE PROJECTOR

Key Advantages

- *Highly Integrated – Projector, wireless charger, Bluetooth speaker, and Android motherboard in one device*
- *Full Ports & Accessories – Complete interface options, including remote control and laser pointer*
- *Bright & Sharp – 2600 ANSI lumens, supports 30-120 inches of clear projection*
- *Smart Adaptive System – Auto focus, 4D keystone correction, and screen-adaptive*
- *Long LED Life – 30,000 hours*
- *Wireless Connectivity – Supports wireless projection, Bluetooth, and Wi-Fi*
- *Suitcase-Style Portable Design – handle + wheels for effortless mobility*
- *All-in-One Mobile Meeting Device – Designed for business travel and flexible meetings*



Corporate Meetings / Trade Shows & Commercial Events / Mobile & Travel Use / Home Entertainment

PAPERLESS CONFERENCE SOFTWARE
Simple · Green · Professional

- Fully Paperless – Eco-friendly and efficient, no printing, no waste.
- Customizable Interface – Show or hide modules as needed, adaptable to any meeting scenario.
- Hidden Function Bar – Clean main interface, one-click access to powerful tools like external signal, screen sharing, and follow the presenter.
- Built-in Web Browsing & PC Mode – Browse the internet or use PC functions without leaving the app.
- Security – Host-only permission control prevents unauthorized operations and data leaks; supports secure one-click data clearing after the meeting.

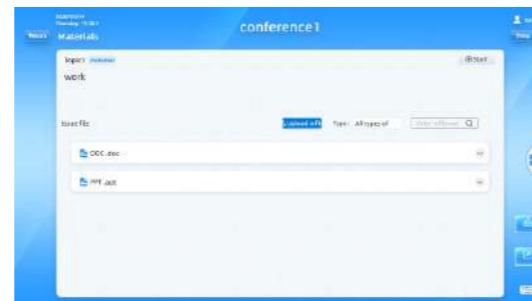
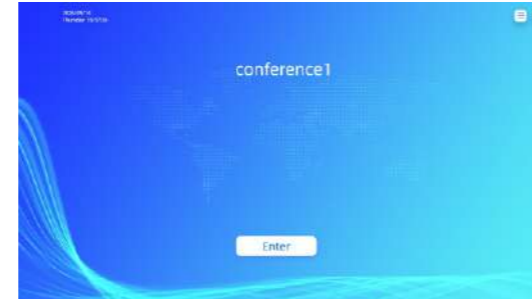

Turn every conference into a smart, seamless & sustainable experience

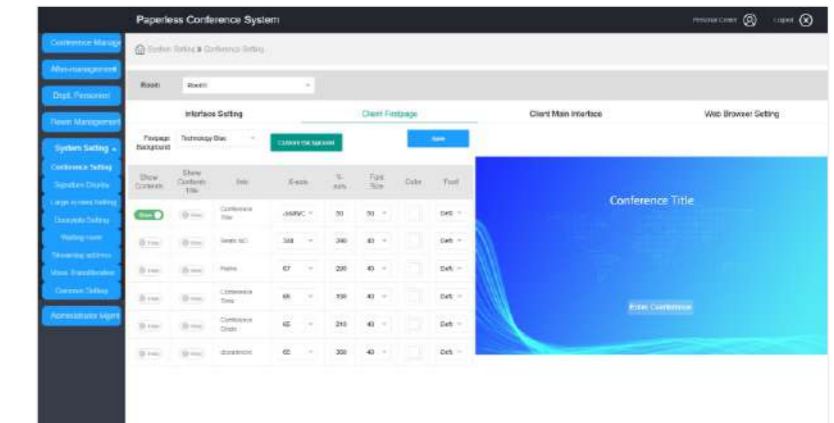
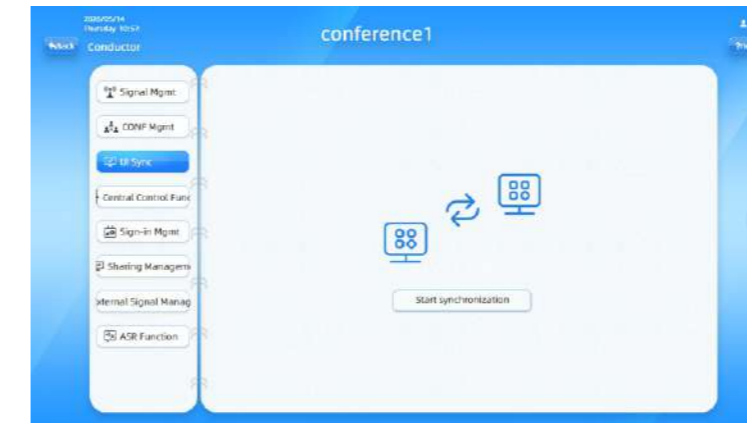

- Complete Meeting Management – Add, start, end, or delete meetings; review all materials after the meeting.
- User & Room Management – Add, edit, or remove attendee information; add or edit meeting room details.
- System Backend & Large Screen Settings – Flexibly configure client background, show/hide modules, web browsing, etc., independently controlling large screen content.



02
**Desktop
Socket**
Safe / Smart / Stylish



MANUALLY ROTARY CABLE CUBBY

Keywords

- 15W Qi charging on top
- ABS material with UL94 certification
- Customizable surface color and texture
- Flexible configurations
- Easy installation with under-table nut



Desktop Socket

Round Type



This desktop hub offers 15W Qi wireless charging and UL94 V-0 ABS construction for safety. Modular design allows flexible combinations of power, USB, HDMI, and network ports—easy future upgrades without replacing the whole unit. Installation uses an under-table clamp nut and fixing rings; no tools needed. Customizable surface color and texture. Ideal for conference rooms, open offices, or home workspaces: safe, clean, and smart power.

Desktop Socket

Round Type

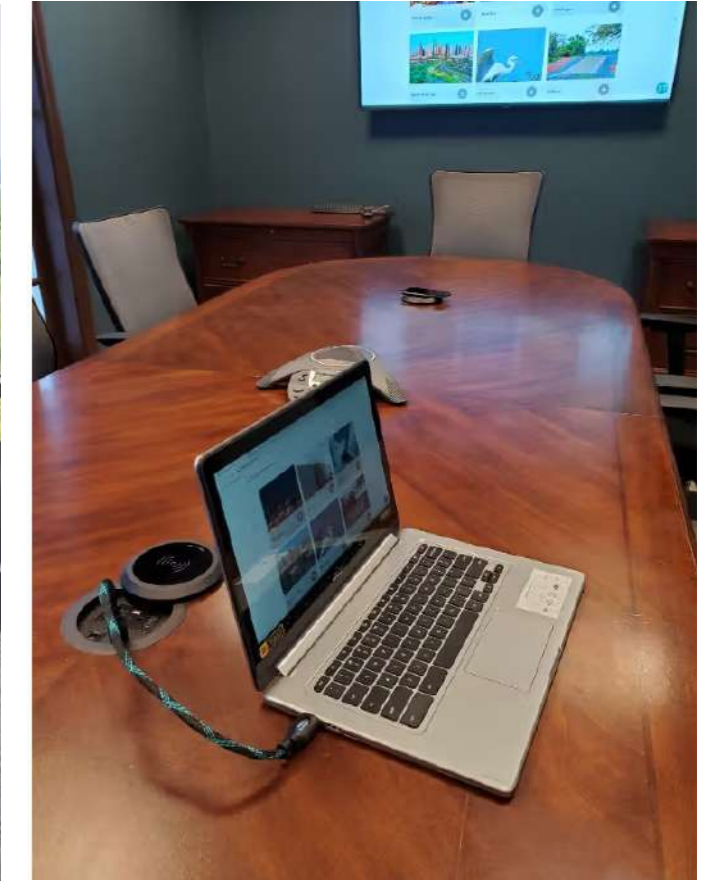

Desktop Socket

Rectangle Type



MULTIPLE PURPOSE CONTROL CUBBY

TS-11B SERIES

Keywords

- Anodized aluminum cover plate
- Flexible configurations
- Ultra-silent opening mechanism
- Customizable exterior and button icons
- User-defined buttons via RS232
- HDBaseT supports HDMI/DP/Type-C max. 70m/100m signal transfer
- Support 4K/1080P 30Hz, 3D, 36bit
- PoC power supply
- RS232 two-way data transfer

Desktop Socket

Rectangle Type

Elegant / Aesthetic / Sophisticated

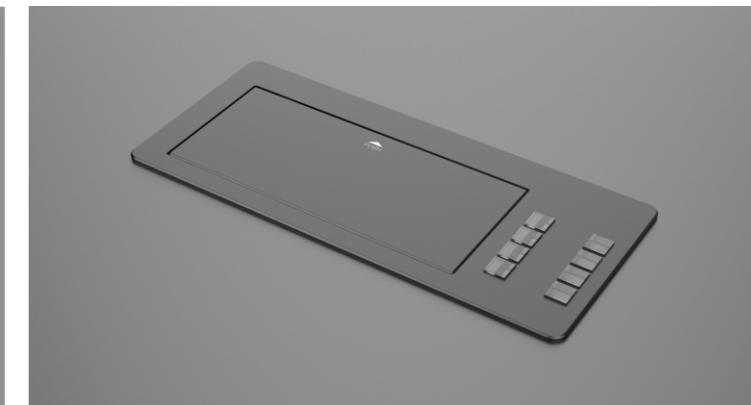



Tailor-made / ultra-silent



Redefining smart life...



M-DESKTOP SOCKET

YH-WG-M 4/3/2 SERIES
Socket without cover



Keywords

- *Modular design for flexible setup*
- *Available in black or silver*
- *Compatible with diverse power standards worldwide*
- *Friendly to installer and user, no tools required*

Desktop Socket

M-Desktop Socket





M-DESKTOP SOCKET

Power Up Any Desk, Anywhere – Instantly

Say goodbye to complicated setups. Our charging insert features a snap-together modular design that lets you customize your power solution in seconds. No screws, no tools.

Designed with installers and end users in mind, it's a true plug-and-play experience. Plus, it works effortlessly with any global power standard—no matter where your clients are. The smart angled inner frame keeps cords neatly tucked away and tangle-free, so desks stay clean and safe.

One solution. Zero hassle. Global ready.



Modular / Tool-free / Universal/Swift

MODULAR DESIGN TO FACILITATE FLEXIBLE SETUP



YH-FG-M 4/3/2 SERIES

Socket with protective cover



The angled inner frame effectively prevents structural interference between the power plug and the frame.



Desktop Power Strip

YH-ZM-M SERIES

Desktop Socket

Desktop power strip

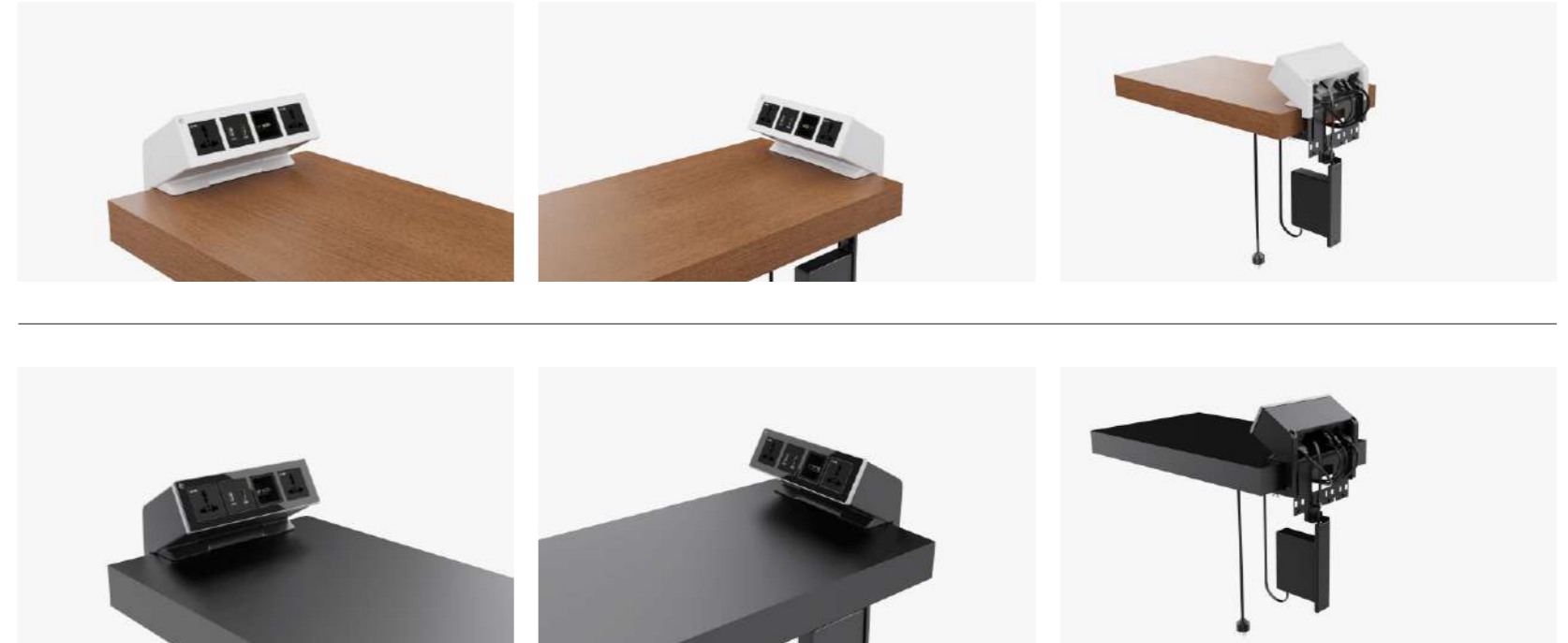

Keywords

- Quick installation – no desktop drilling required
- Modular design for flexible interface configuration
- Compatible with global power standards
- Available in White or Black



**Under-desk
Power
Strip**
YH-ZX-M SERIES

Desktop Socket

Under-desk power strip

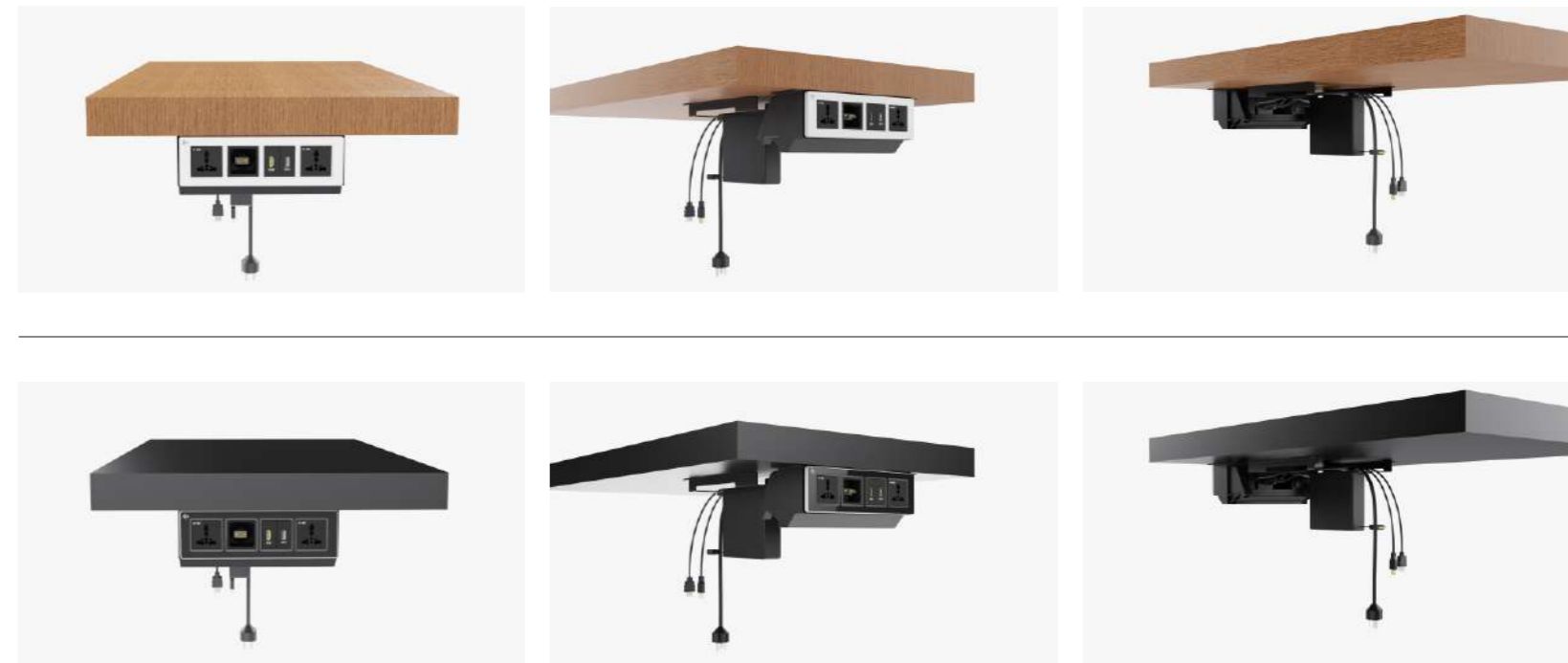





Keywords



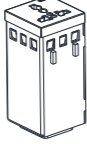
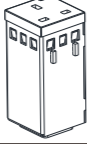
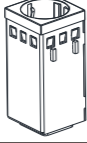
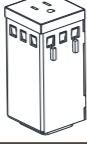
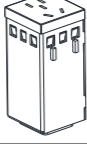
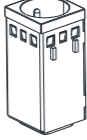

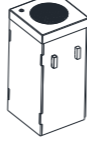
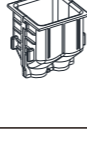
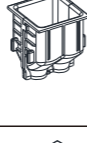

- Quick installation
- Compatible with global power standards
- Modular design for flexible interface configuration
- Available in White or Black

Available Modules

Modules color: RAL9005

Model	Description	Specs	Figure
DM-UN	Universal standard power socket	Input 100-250V ~50/60Hz 10A Fuse - 10A 250V OUT-Maximum 10A	
DM-GB	United kingdom power socket	Input 100-250V ~50/60Hz 10A Fuse - 10A 250V OUT-Maximum 10A	
DM-DE	Germany(Western Europe)power socket	Input 100-250V ~50/60Hz 10A Fuse - 10A 250V OUT-Maximum 10A	
DM-US	American power socket	Input 100-250V ~50/60Hz 10A Fuse - 10A 250V OUT-Maximum 10A	
DM-CH	Chinese standard power socket	Input 100-250V ~50/60Hz 10A Fuse - 10A 250V OUT-Maximum 10A	
DM-FR	French standard socket	Input 100-250V ~50/60Hz 10A Fuse - 10A 250V OUT-Maximum 10A	

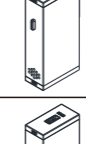
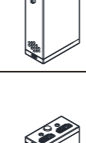
Model	Description	Specs	Figure
KM-CC	Fast charging module+extendable cable	Input 100-250V ~50/60Hz 10A Output TYPE-C: 5V3A/9V3A/12V3A/15V3A/20V3.25A (65W) USB-A :5V3A/9V2A/12V1.5A <i>Scalablecable:</i> 5V3A/9V3A/12V3A/15V3A/20V3.25A (65W) Cable length:70mm	
KM-BL	Supports Bluetooth connection and playback for devices such as mobile phones and tablets	Input 5V-1A	
KM-2C	Pass-through module with 2 holes.Accommodates cables up to 10 mm in diameter	2hole	
KM-1C	Pass-through module with 1 hole.Accommodates cables up to 10 mm in diameter	1hole	
KM-1RJ45	Passive module with 1 RJ45 port input 1 female output	S/FTP CAT6a	
RET-RJ45	RJ45 retractable cable	RJ45, retractable length 1500mm, fixed end 250-600mm	

Model	Description	Specs	Figure
RET-TYPE-C	Type-C retractable cable	3in1, retractable length 1500mm, fixed end 250-600mm Data transfer speed: 3.1 Gen, 10Gbps max. Resolution: 4K Charging speed: 100W max.	
RET-USB-A	USB-A retractable cable	USB-A 3.0, retractable length 1500mm, fixed end 250-600mm Data transfer speed: 5Gbps max.	
RET-HDMI	HDMI retractable cable	HDMI 2.0, retractable length 1500mm, fixed-end 250-600mm Resolution: 4K@60Hz,	
KM-2RJ45	Passive module with 2 RJ45 ports input 2 female outputs	S/FTP CAT6a	
KM-TC	Passive module with 1 USBC FF port input female .Output - 1USBC female	Full feature - 4K 10Gbps ,65w power charging	
KM-UB	Passive module with 1 USBA FF port input female .Output - 1USBA female	5Gbps.	
KM-2H/1	Passive module with 2 HDMI port input female .Output - 1HDMI female.And it has a switching function.	4K-60Hz	









Model	Description	Specs	Figure
KM-AC	1 USB-A + 1TYPE-C	Input 100-250V ~50/60Hz 10A Output TYPE-C: 5V3A/9V3A/12V3A/15V3A/20V3.25A (65W) USB-A :5V3A9V/2A 12V1.5A	
KM-1H	Passive module with 1 HDMI port input female .Output - 1HDMI female	4K-30Hz	
KM-KB	Fills the vacant installation position		

Table Cutout Dimensions

Model	Product images	Table opening size
M4		203*84mm(7.99" X 3.31")
		200*57mm(7.87" X 2.24")
M3		158*84mm(6.22" X 3.31")
		155*57mm(6.1" X 2.24")
M2		113*84mm(4.45" X 3.31")
		110*57mm(4.33" X 2.24")

We recommend using the template (packed with device) for maximal accuracy

Table thickness:20-80mm (0.787-3.15")

Desktop Socket

Public Phone Charging Station

PUBLIC PHONE CHARGING STATION

Universal · Tidy · Powerful



YH-CDZX SERIES

Keywords

- 65W USB-C x4 (laptop-ready) + 15W wireless + 6 AC outlets – one station for all your devices
- Retractable cord and rear tablet holder – tangle-free and tidy
- Sleek upright design (450×250×918 mm) – powerful yet space-saving
- Movable – easy to reposition
- Available in White or Black

Desktop Socket

Public Phone Charging Station

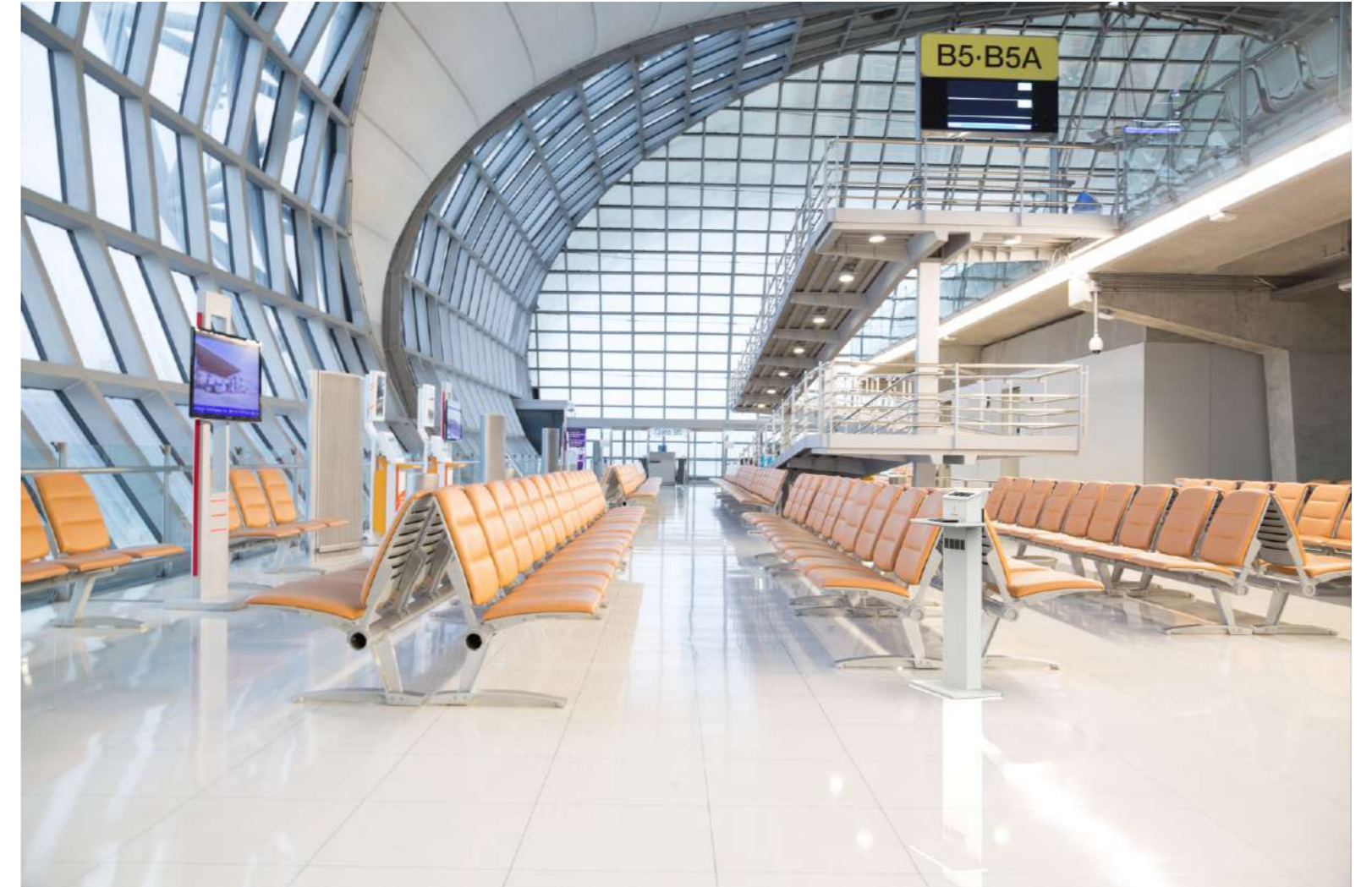

Airport Lounges / Train Stations / Hotel Lobbies & Conference Areas / Tourist Rest Areas & Co-working Spaces

03 Lectern

Anti-glare touchscreen, built-in PC, height-adjustable. Sleek and perfect for lecture halls & conference rooms.





DIGITAL LECTERN



Keywords

- 15.6-inch touchscreen with anti-glare treatment
- Built-in PC
- Adjustable height
- Dual mic with standard XLR connector
- Electronic pen
- Elegant appearance

ENGINEERED FOR PRESENTERS



Keywords

- 21.5-inch touchscreen with anti-glare treatment
- Built-in PC
- Drawer for mouse and keyboard
- Adjustable height
- Dual mic with standard XLR connector
- 12.6-inch nameplate, free software available
- Extended HDMI inputs and outputs

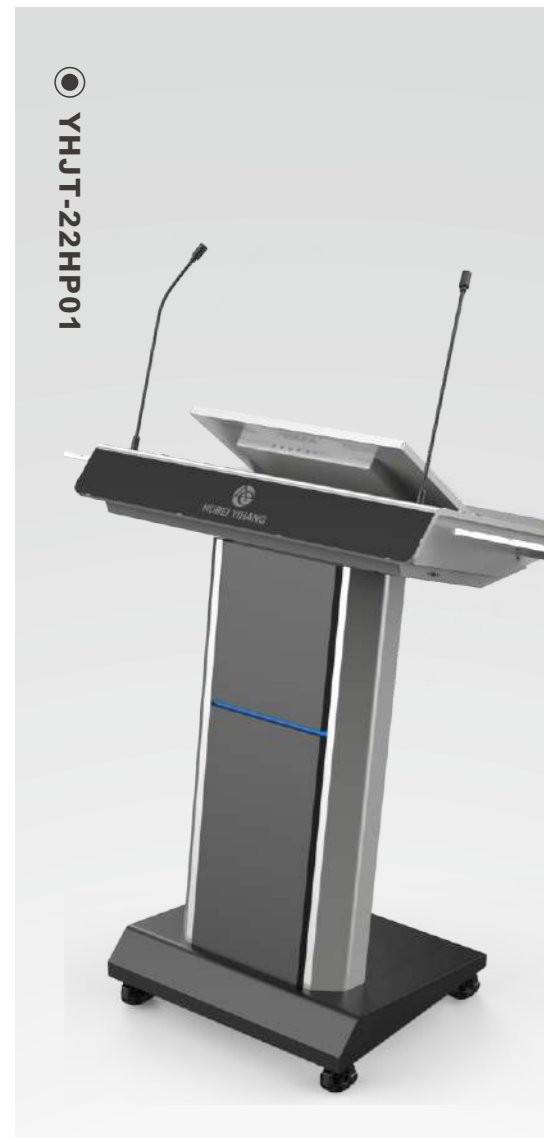

DIGITAL LECTERN

Keywords

- 21.5-inch touchscreen with anti-glare treatment
- Built-in PC
- Drawer for mouse and keyboard
- Adjustable height
- Dual mic with standard XLR connector
- Extended HDMI inputs and outputs





PREMIUM SMART INTERACTIVE LECTERN

Keywords

- 21.5-inch touchscreen with anti-glare treatment
- Built-in PC
- Drawer for mouse and keyboard
- Adjustable height
- Cabinet for storage
- Flexible input/output via built-in cable interfaces

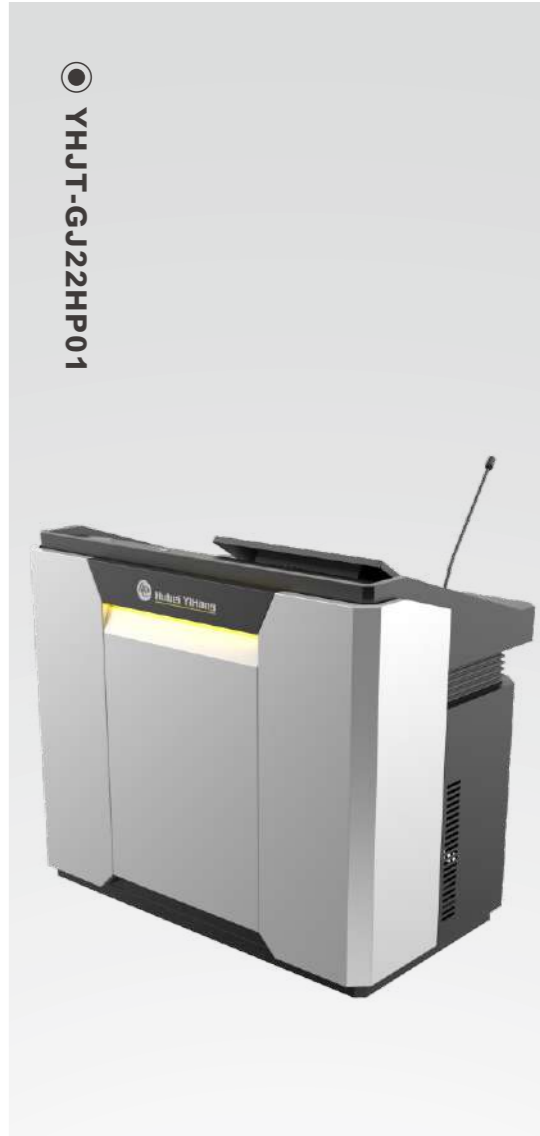

SMART PODIUM PRO

© YHJT-19HP01



Keywords

- *Wireless charging built into the front panel, compatible with Qi-enabled devices*
- *5-meter retractable power cord*
- *One-touch height adjustment*
- *Magnetic logo, freely replaceable (customizable)*
- *Includes laser pointer with wireless microphone support*
- *18.5-inch touchscreen all-in-one display*
- *Wooden tabletop*



Meeting Rooms / Auditoriums / Classrooms / Hotels / Government / Courtrooms / Training Rooms



04 Control Console

Ergonomic, modular,
and durable. Multi-device,
safety-compliant. Ideal
for 24/7 control rooms.



OPERATOR CONSOLE

43.8" Screen | Smaller Sizes Available

Keywords

- *Ergonomic Design*
- *Sturdy Construction for Long-Term Durability*
- *Modular Design for Easy Expansion and Maintenance*

